

LW22



Schneidsatz Enterprise E22 (L&W)

Lochscheibe 3 mm mit
Nabe und 4 Nuten,
1 Messer



Cutting system
Enterprise E22 (L&W)
Plate 3 mm with hub
and 4 slots, 1 knife

Stopfwolf	Stuffing mincers	LW22	
Schneidsystem	Cutting system	Enterprise E22	
Lochscheiben- durchmesser	Diameter of perforated plate	mm	83
Schüsselvolumen- Standard	Bowl standard volume	Ltr	6
Schüsselvolumen-Groß (Optional)	Enlarged bowl volume (Optional)	Ltr	-
Förderleistung bei 3mm Lochscheibe*	Hourly output with perforated plate of 3mm*	kg/h	350
Motorleistung / IP55	Motor capacity / IP55	kW	1,25
Gewicht netto	Weight net	kg	60 - 62

* Bei 3 mm Endlochscheibe, Verarbeitung von kleinen Frischfleischstücken
0 / -1° Grad ohne Zusätze

* with 3 mm final hole plate, processing of small beef or pork pieces
0 / -1° degree without ingredients

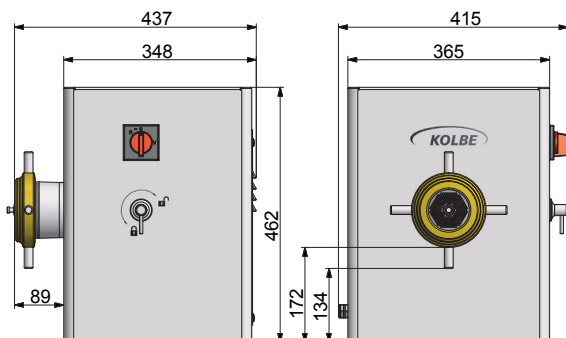

Technische Änderungen vorbehalten – Specifications subject to change without notice

LW82



Schneidsatz Unger H82 (L&W)

Vorschneider,
Lochscheibe 3 mm,
1 Messer, breiter
Einlegering



Cutting system
Unger H82 (L&W)
Precutter, 1 knife,
3 mm hole plate

Stopfwolf	Stuffing mincers	L82	
Schneidsystem	Cutting system	Unger H82	
Lochscheiben- durchmesser	Diameter of perforated plate	mm	82
Schüsselvolumen- Standard	Bowl standard volume	Ltr	6
Schüsselvolumen-Groß (Optional)	Enlarged bowl volume (Optional)	Ltr	-
Förderleistung bei 3mm Lochscheibe*	Hourly output with perforated plate of 3mm*	kg/h	350
Motorleistung / IP55	Motor capacity / IP55	kW	1,25
Gewicht netto	Weight net	kg	62 - 64

* Bei 3 mm Endlochscheibe, Verarbeitung von kleinen Frischfleischstücken
0 / -1° Grad ohne Zusätze

* with 3 mm final hole plate, processing of small beef or pork pieces
0 / -1° degree without ingredients

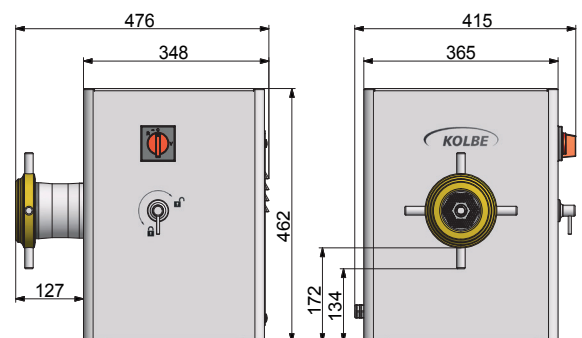

Technische Änderungen vorbehalten – Specifications subject to change without notice